

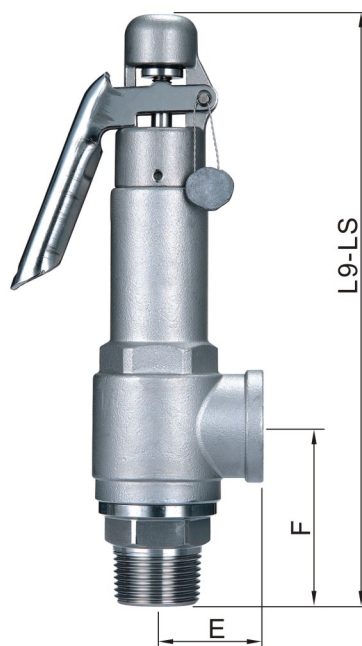

# 不銹鋼安全閥 STAINLESS STEEL SAFETY VALVES

L9S 密閉式 Sealing 1/2"~2"

L9-LS 手拉式 Lever 1/2"~2"

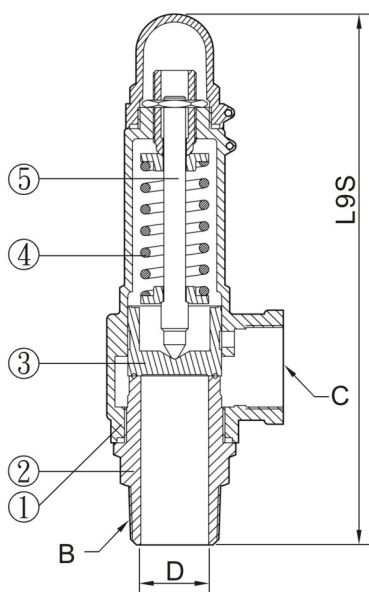

## 尺寸表 Dimensions

(密閉式 Sealing)

單位 Unit:mm

(手拉式 Lever)

單位 Unit:mm

項目 Item	入口 Inlet	出口 Outlet	閥座徑 Valve seat orifice	揚程 Lift	重量 Wt. kg	尺寸 Size		重量 Wt. kg
						L9S	L9-LS	
1/2"	1/2"	1/2"	13	0.52	0.5	142	168	0.6
3/4"	3/4"	3/4"	19	0.76	0.7	164	190	0.8
1"	1"	1"	25	1.00	1.2	200	222	1.3
1-1/4"	1-1/4"	1-1/4"	32	1.28	2.0	232	248	2.0
1-1/2"	1-1/2"	1-1/2"	38	1.52	2.6	256	272	2.7
2"	2"	2"	50	2.00	4.3	283	306	4.4

## 材質表 General Material

序號 NO.	零件 Parts Name	型式 Model	L9S 密閉式 Sealing	L9-LS 手拉式 Lever
1	閥體 Valve Body		CF8 (不銹鋼)	
2	閥座 Valve Seat		SUS 304 or CF8(不銹鋼)	
3	閥盤 Disc		SUS 304 or CF8(不銹鋼)	
4	彈簧 Spring		SUS 304 (不銹鋼)	
5	閥桿 Stem		SUS 304 (不銹鋼)	
使用壓力 Working Pressure			0.3~2 kgf/cm <sup>2</sup>	2.1~10 kgf/cm <sup>2</sup> 11~20 kgf/cm <sup>2</sup>
使用溫度 Working Temp			-196 °C~290 °C	
使用流體 Working Fluid			非腐蝕性氣體、腐蝕性氣體、 空氣、蒸氣 Noncorrosive Gas、Corrosive Gas、 Air、Steam	非腐蝕性氣體、腐蝕性氣體、 空氣、蒸氣 Noncorrosive Gas、Corrosive Gas、 Air、Steam

L9S 2" L9-LS 2" Working Pressure 11-20kgf/cm<sup>2</sup>, Valve Seat orifice(D) 40mm