

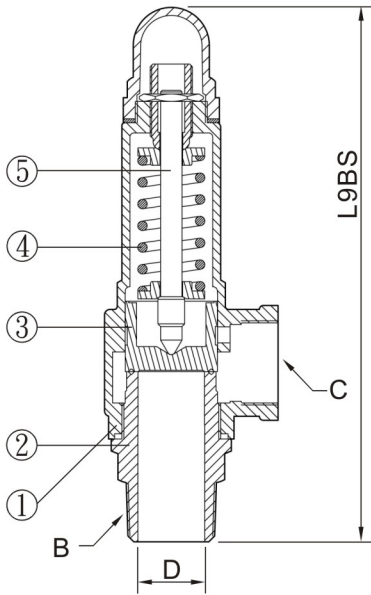

青(砲金)銅安全閥 BRONZE SAFETY VALVES

L9BS 密閉式 Sealing 1/2"~2"

L9-LBS 手拉式 Lever 1/2"~2"



尺寸表 Dimensions

(密閉式 Sealing)

單位 Unit:mm

(手拉式 Lever)

單位 Unit:mm

項目 Item	入口 Inlet	出口 Outlet	閥座徑 Valve seat orifice	揚程 Lift	重量 Wt. kg	尺寸 Size		重量 Wt. kg
						L9BS	L9-LBS	
1/2"	1/2"	1/2"	13	0.52	0.5	145	168	0.6
3/4"	3/4"	3/4"	19	0.76	0.8	167	190	0.8
1"	1"	1"	25	1.00	1.3	202	223	1.4
1-1/4"	1-1/4"	1-1/4"	32	1.28	2.1	233	248	2.2
1-1/2"	1-1/2"	1-1/2"	38	1.52	2.8	257	272	2.9
2"	2"	2"	50	2.00	4.5	283	299	4.7

材質表 General Material

序號 NO.	零件 Parts Name	型式 Model	L9BS 密閉式 Sealing	L9-LBS 手拉式 Lever
1	閥體 Valve Body		Cast Bronze 青(砲金)銅	
2	閥座 Valve Seat		SUS304 or CF8 (不銹鋼)	
3	閥盤 Disc		SUS304 or CF8 (不銹鋼)	
4	彈簧 Spring		Steel (鋼)	
5	閥桿 Stem		Brass (黃銅)	
使用壓力 Working Pressure			0.3~2 kgf/cm ²	2.1~10 kgf/cm ² 11~20 kgf/cm ²
使用溫度 Working Temp			-45 °C~185 °C	
使用流體 Working Fluid			非腐蝕性氣體、空氣、蒸氣 Noncorrosive Gas、Air、Steam	非腐蝕性氣體、空氣、蒸氣 Noncorrosive Gas、Air、Steam